

W - 1,81
N - 0,00
H_N - 0,59

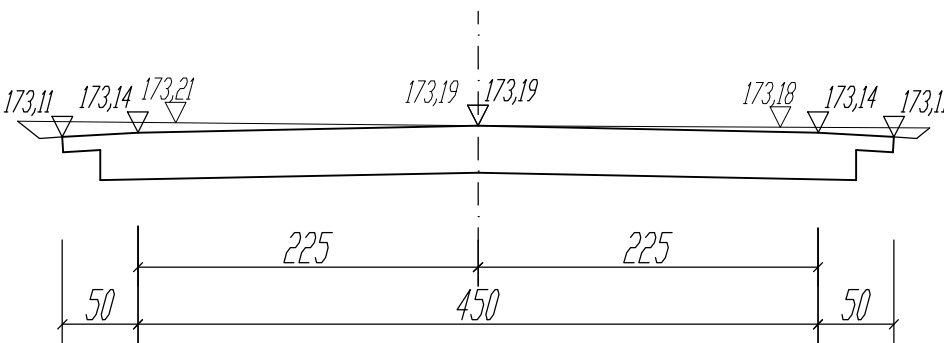

W - 1,91
N - 0,00
H_N - 0,64

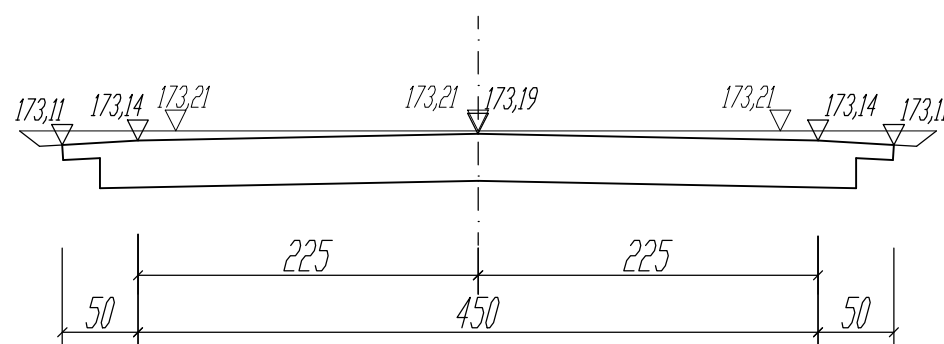

W - 1,29
N - 0,49
H_N - 1,79

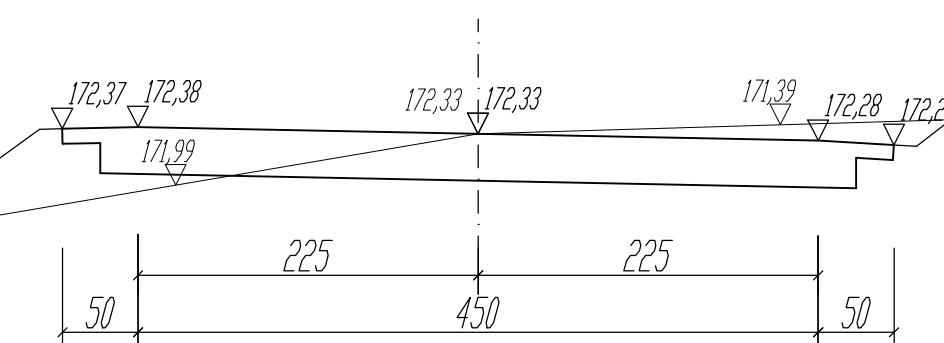

W - 0,57
N - 0,27
H_N - 1,03

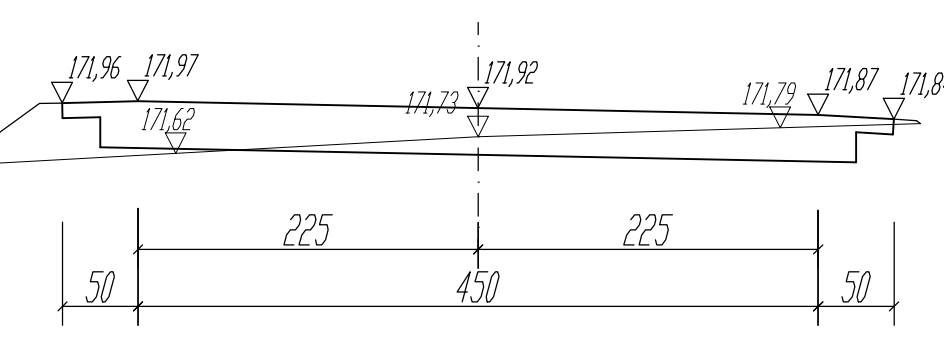

W - 1,37
N - 0,00
H_N - 0,65

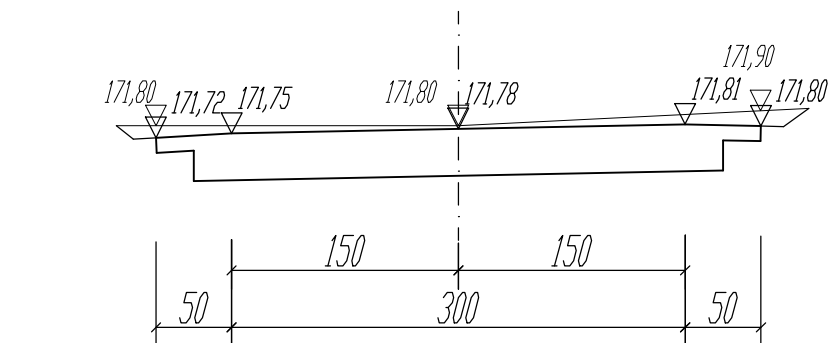

W - 0,54
N - 0,09
H_N - 0,73

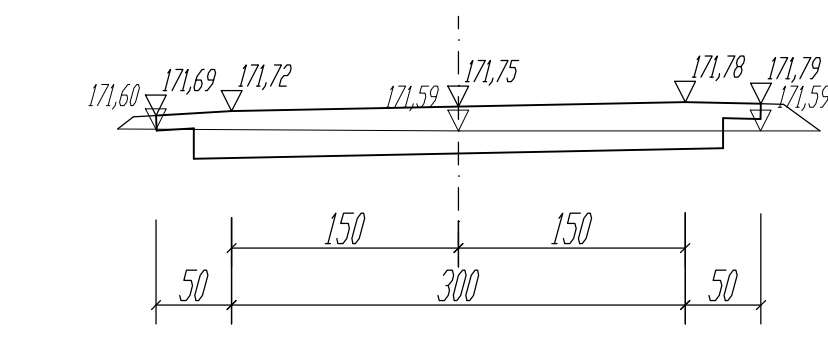

W - 0,48
N - 0,12
H_N - 0,81

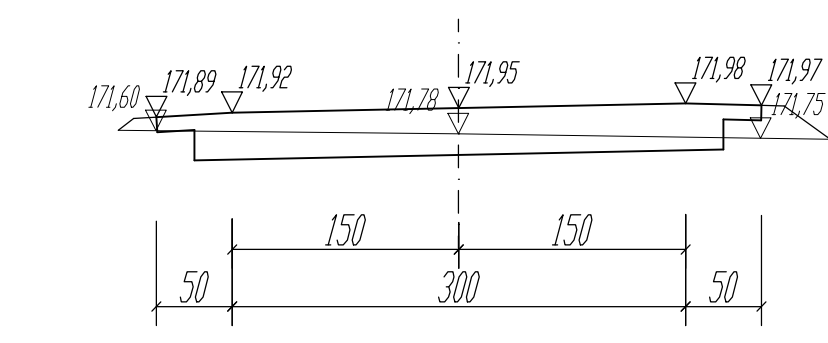

W - 0,52
N - 0,06
H_N - 0,64

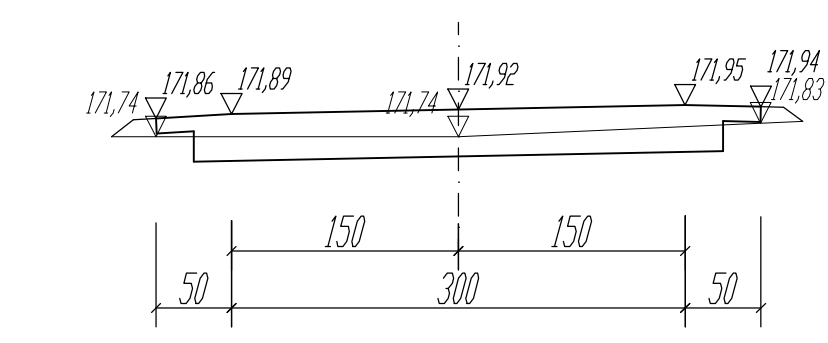

W - 0,75
N - 0,03
H_N - 0,46

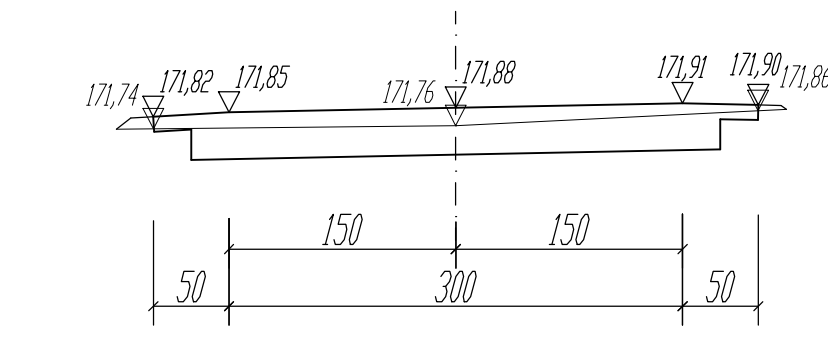

W - 0,81
N - 0,02
H_N - 0,49

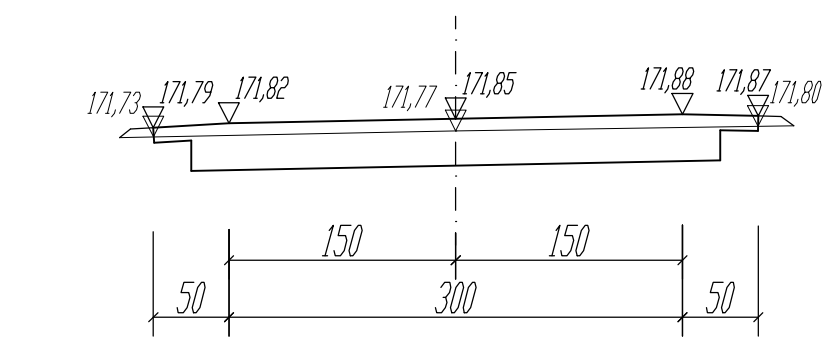

W - 1,52
N - 0,00
H_N - 0,69

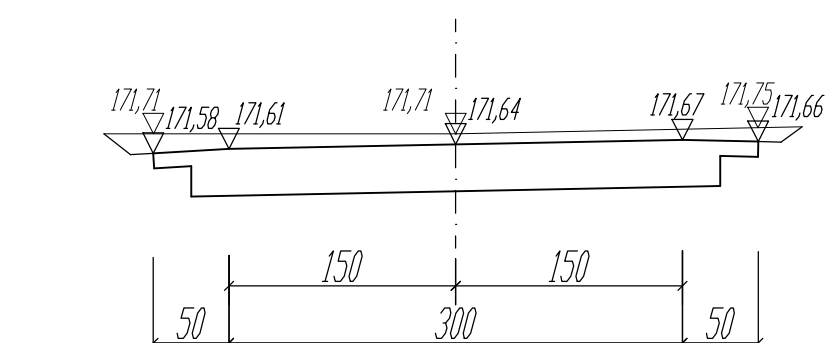

W - 1,14
N - 0,05
H_N - 1,24

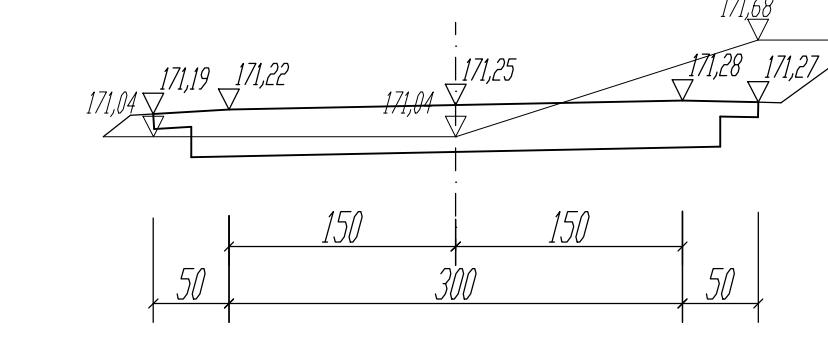

W - 1,78
N - 0,00
H_N - 0,80

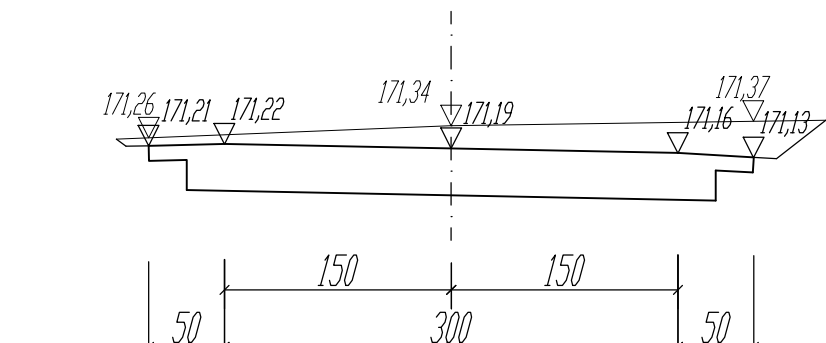

W - 0,48
N - 0,11
H_N - 0,71

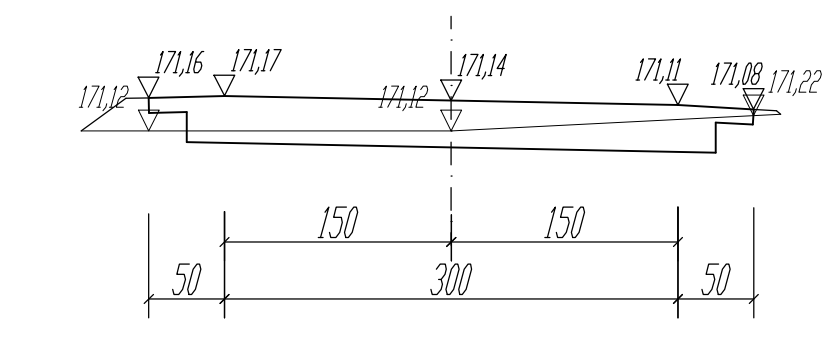

W - 0,67
N - 0,11
H_N - 0,78

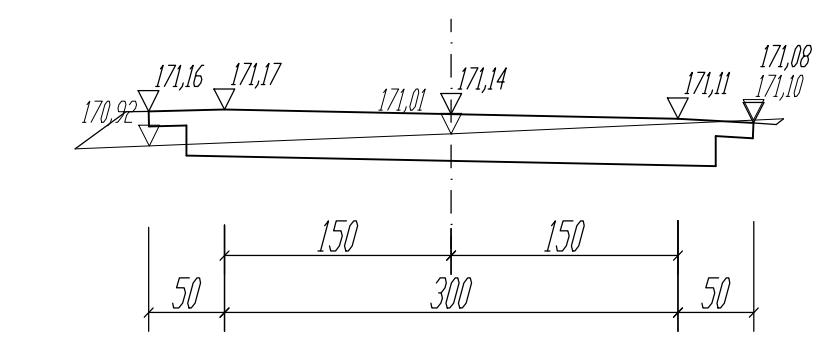

W - 0,50
N - 0,16
H_N - 0,87

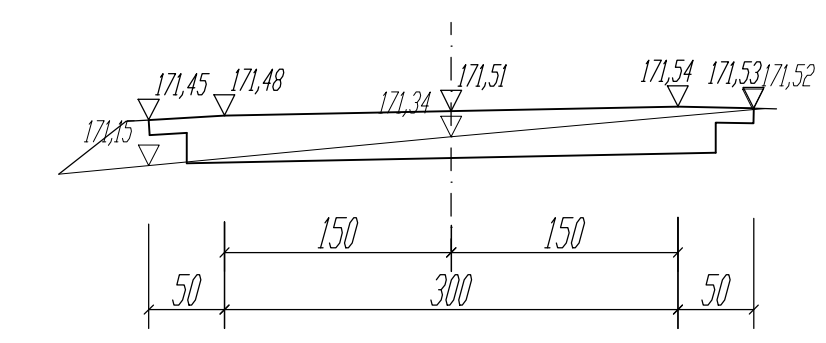

W - 0,71
N - 0,09
H_N - 0,75

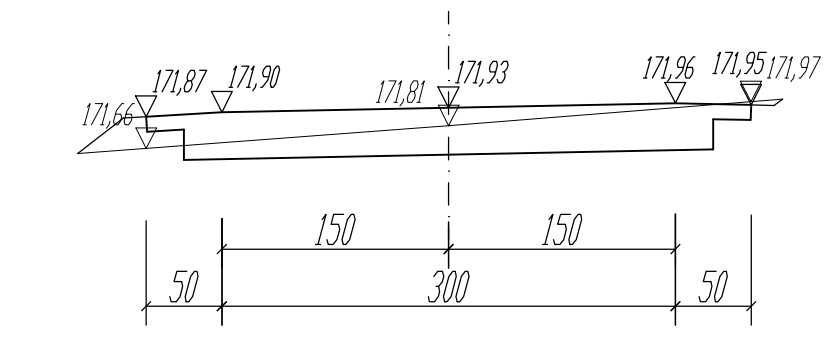

W - 0,59
N - 0,13
H_N - 0,89

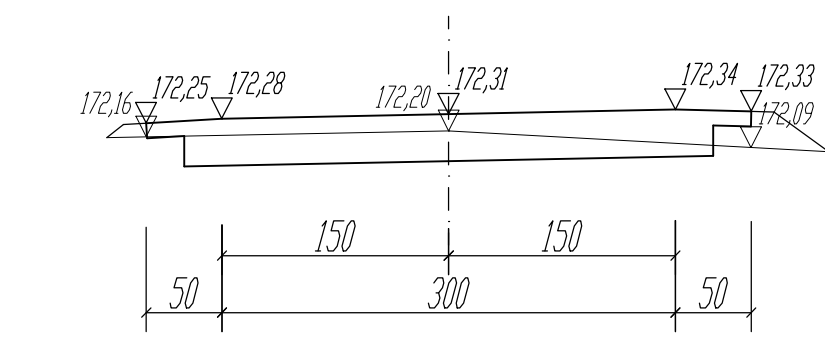

W - 0,62
N - 0,09
H_N - 0,75

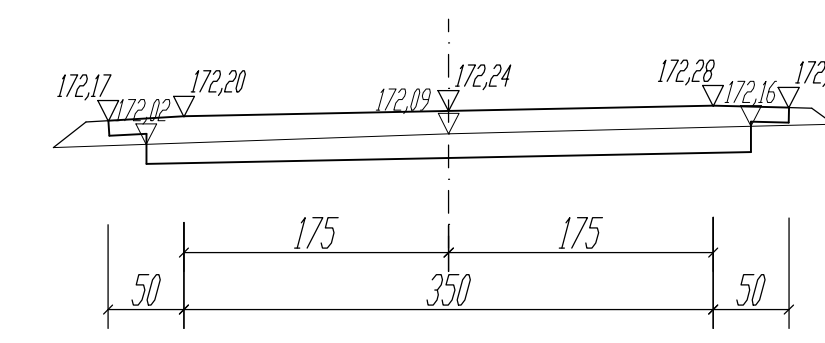

W - 1,00
N - 0,01
H_N - 0,53

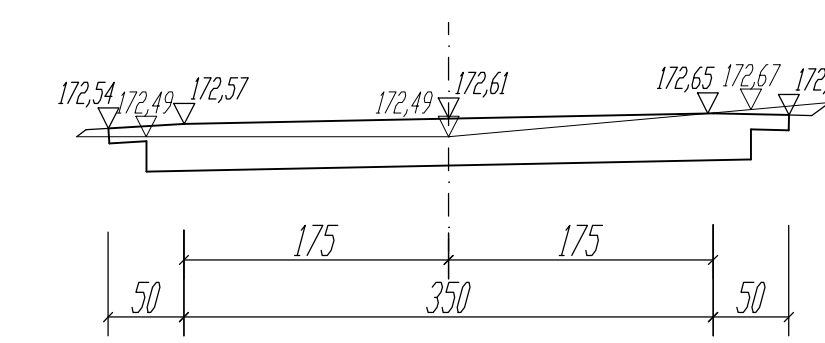

W - 0,90
N - 0,06
H_N - 0,79

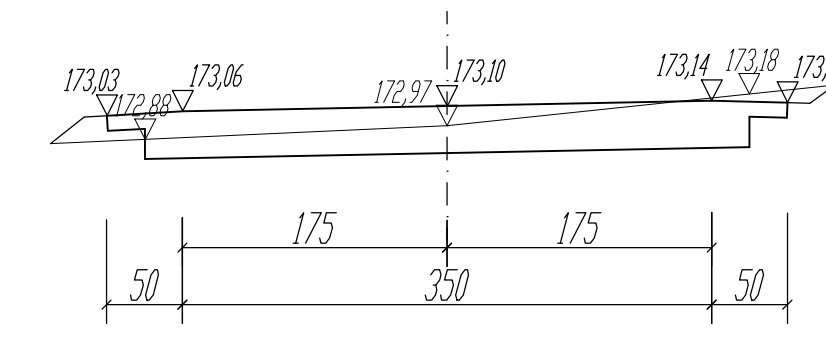

W - 0,45
N - 0,51
H_N - 1,89

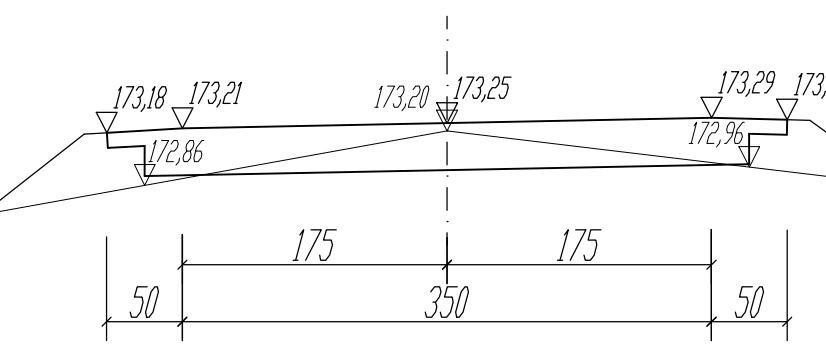

W - 0,91
N - 0,02
H_N - 0,49

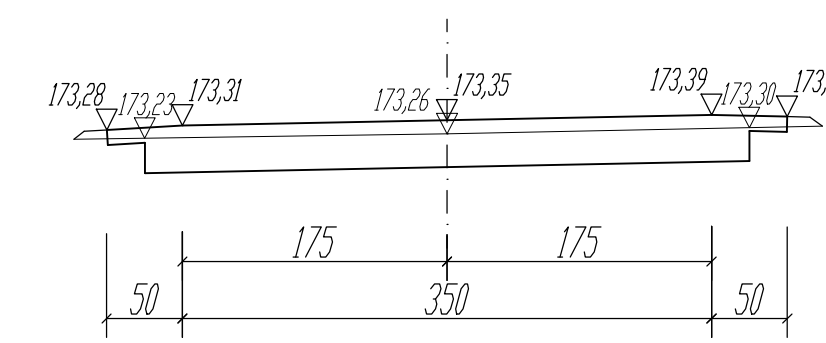

W - 0,94
N - 0,03
H_N - 0,48

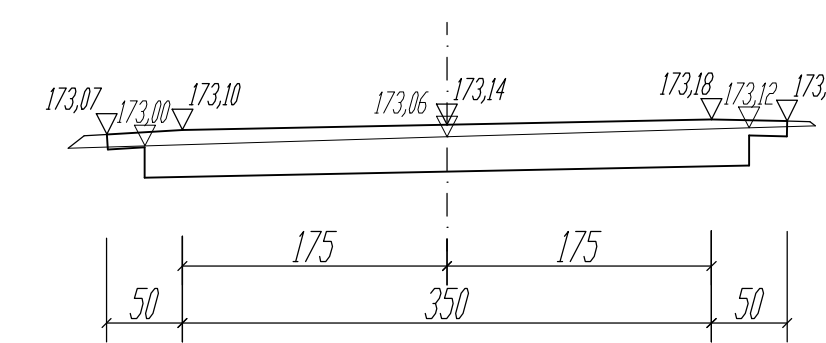

W - 1,24
N - 0,01
H_N - 0,41

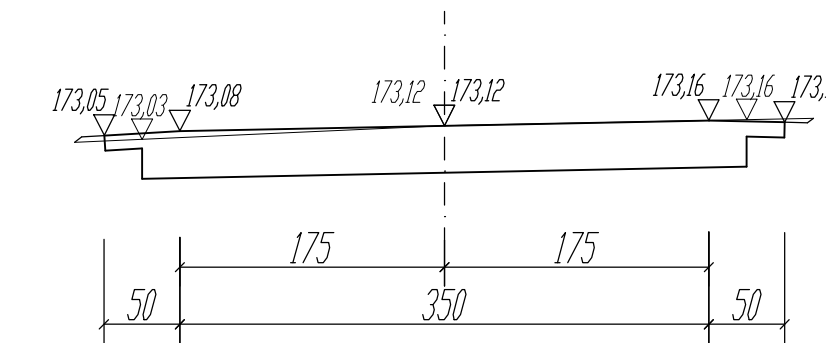

INWESTOR:	GMINA REŃSKA WIEŚ 47-208 Reńska Wieś; ul. Pawłowicka 1		
	USŁUGI PROJEKTOWE I NADZÓR BUDOWLANY inż. Ryszard Warmiński ul. Strażaków 15; 47-208 Gieratowice		
	BUDOWA DRÓGI DOJAZDOWEJ DO GRUNTÓW ROLNYCH OD PRZEJAZDU KOLEJOWEGO W WIEKSIJCACH DO UL. FABRYCZNEJ W REŃSKIEJ WSI		
	PRZEKROJE POPRZECZNE		
Projektant:	inż. Ryszard Warmiński	Skala 1:100	4